



Applied Pulsed Power™

A Division of Silicon Power Corporation

280 Great Valley Parkway
Malvern, PA 19355-1308

Phone: 610-407-4700
www.appliedpulsedpower.com

Model S41 Self Powered Auto Turn-Off Switch Module

Page 1 of 2



The package consists of one (1) GTO based thyristor with trigger circuit for same and one (1) 4000V anti-parallel diode. The package is an epoxy shell with four (4) clearance holes for size 10 screws for mounting and two (2) 10-32 female terminals for attaching the anode and cathode. Lastly, there is a female SMA connector for the trigger

To trigger the switch, a 10mA 10V signal is required. The pulse width of the trigger signal should be at least 10 μ S and no longer than the width of the forward current pulse going through the switch. The trigger signal is isolated from the switch by an optical isolator which results in a 2 μ S delay between the triggering pulse and the closing of the switch. Internal capacitances charged from the anode to cathode voltage stores the energy to turn on and off the switch. An internal current sensor measures the switch current. When this current is greater than 200A in the reverse direction, the module starts to turn off the thyristor. Tests have shown that the thyristor will turn off given 100 μ S between when the reverse current reaches 200A and when it next reaches 0A.

The charge time of the internal capacitances limits the maximum repetition rate to around 1 pulse per minute. Faster rates may result in insufficient energy stored in the internal capacitors to turn off the switch.

It is also not recommended to operate the module at an anode voltage of less than 300V.

Model S41 Self Powered Auto Turn-Off Switch Module

Page 2 of 2

Operational Specifications

Maximum Tested Thyristor Peak Forward Voltage	3kV
Rated Diode Blocking Voltage	4kV
Trigger Voltage Isolation	5kV (1 minute)
Maximum Recommended Trigger Repetition Rate	1ppm
Expected Trigger Delay	2 μ S
Designed Package Voltage Isolation, Anode to Base	10kV
Rated Peak Forward Current (150 μ S half sine current waveform)	3kA
Rated Peak Reverse Current (150 μ S half sine current waveform)	2kA

Package Drawing

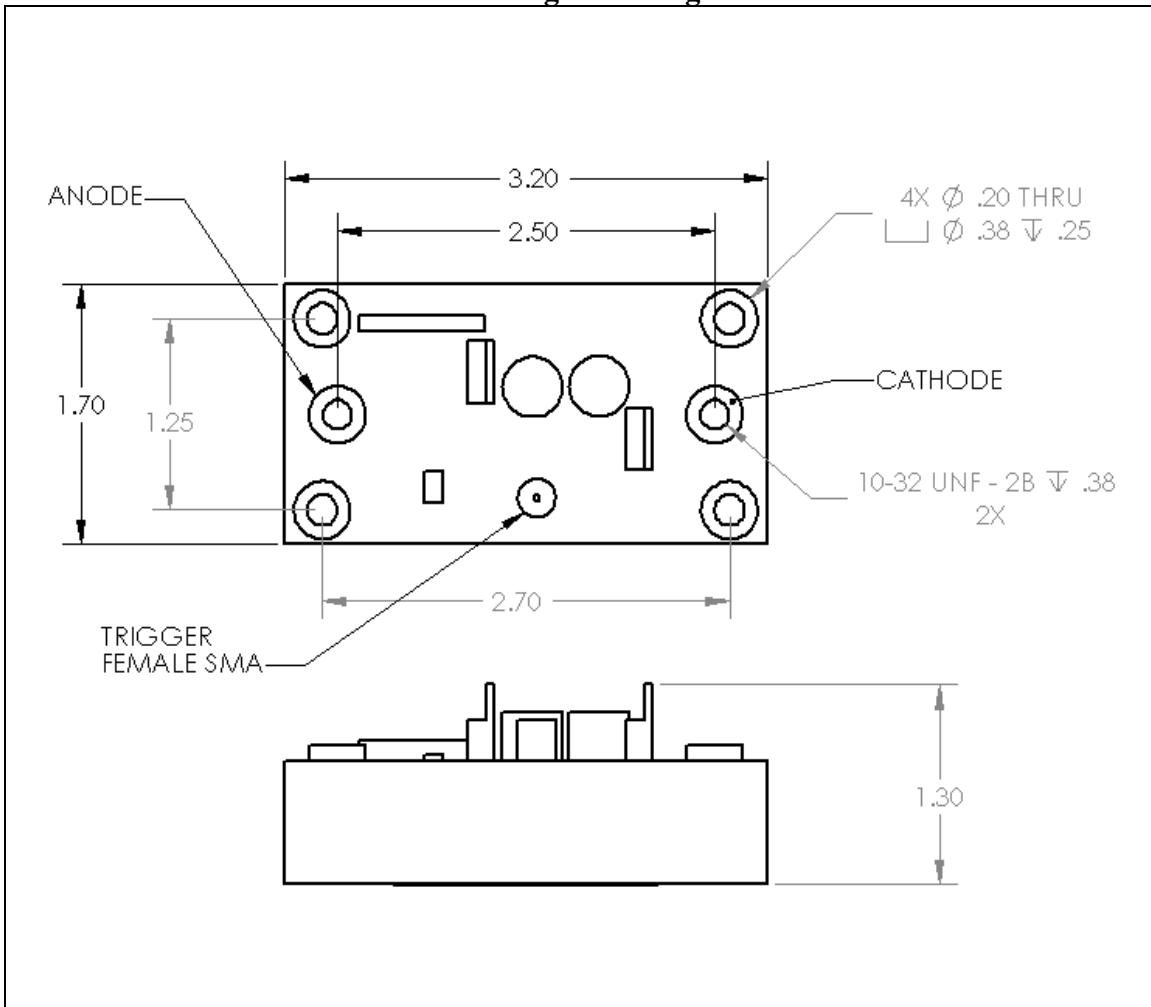

Simplified Circuit Schematic

