

Description

This current controlled Solidtron™ (CCS) discharge switch is an n-type Thyristor in a high performance silicon device. The device gate is similar to that found on a traditional GTO Thyristor.

The CCS features the high peak current capability and low On-state voltage drop common to SCR thyristors combined with high di/dt capability. This semiconductor is intended to be a solid state replacement for spark or gas type devices commonly used in pulse power applications.

It's small size and low profile make it extremely attractive for high di/dt applications where stray series inductance must be kept to a minimum.

Features

- 3000V Peak Off-State Voltage
- 5 kA Repetitive Ipk Capability
- 25 KA/uS di/dt Capability
- Low On-State Voltage
- Low trigger current
- Low Inductance Package

Package

Size - 9

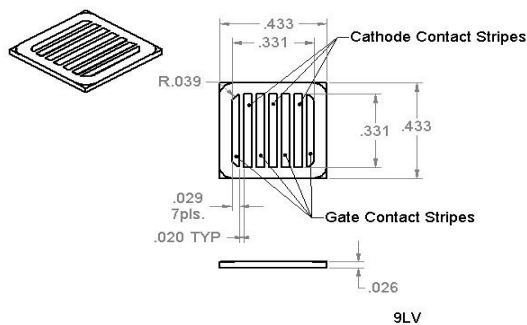

Schematic Symbol

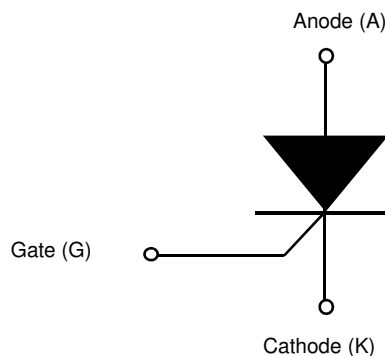

Absolute Maximum Ratings

	SYMBOL	VALUE	UNITS
Peak Off-State Voltage	V_{DRM}	3	kV
Peak Reverse Voltage	V_{RRM}	-5	V
Off-State Rate of Change of Voltage Immunity*	dv/dt	1	kV/uSec
Continuous Anode Current at $T_j = 125^\circ\text{C}$	I_{A110}	50	A
Repetitive Peak Anode Current (Pulse Width=10uSec)	I_{ASM}	5.0	kA
Nonrepetitive Peak Anode Current (Pulse Width=10uSec)	I_{ASM}	8	kA
Rate of Change of Current	di/dt	25	kA/uSec
Peak Gate Current (1 uS)	I_{Gpk}	50	A
Max. Reverse Gate-Cathode Voltage	V_{GR}	-9	V
Maximum Junction Temperature	T_{JM}	125	$^\circ\text{C}$
Maximum Soldering Temperature (Installation)		260	$^\circ\text{C}$

This **SILICON POWER** product is protected by one or more of the following U.S. Patents:

5,521,436	5,446,316	5,105,536	5,209,390	4,958,211	5,206,186	4,857,983	5,082,795	4,644,637
5,585,310	5,557,656	5,777,346	5,139,972	5,111,268	5,757,036	4,888,627	4,980,741	4,374,389
5,248,901	5,564,226	5,446,316	5,103,290	5,260,590	5,777,346	4,912,541	4,941,026	4,750,666
5,366,932	5,517,058	5,577,656	5,028,987	5,350,935	5,995,349	5,424,563	4,927,772	4,429,011
5,497,013	4,814,283	5,473,193	5,304,847	5,640,300	4,801,985	5,399,892	4,739,387	5,293,070
5,532,635	5,135,890	5,166,773	5,569,957	5,184,206	4,476,671	5,468,668	4,648,174	

Performance Characteristics <small>T_J=25°C unless otherwise specified</small>			Measurements			
Parameters	Symbol	Test Conditions	Min.	Typ.	Max.	Units
Anode to Cathode Breakdown Voltage	V _{DR}	V _{GK} =0, I _A =100uA	3			kV
Anode-Cathode Off-State Current	I _D	V _{GK} =0V, V _{AK} =3000V	T _J =25°C	<30	100	uA
			T _J =125°C	80	250	uA
Turn-On Threshold Current	V _{GK(TH)}	V _{AK} =V _{GK} , I _{AK} =1mA, see Note 1		5		mA
Gate-Cathode Leakage Current	I _{GK(IK)}	V _{GK} =0V, see Note 1			20	uA
Anode-Cathode On-State Voltage	V _T	I _T =400A I _g = 500 mA	T _J =25°C	3.8		V
			T _J =125°C	4.9		V
Turn-on Delay Time	t _{D(ON)}	6 uF Capacitor discharge		150		ns
Pk Rate of Change of Current (measured)	di/dt	V _{AK} = 2.1 kV T _J =25°C		4		kA/us
Peak Anode Current	I _P	R _{gk} = 10 ohms		4		kA
		Gate di/dt =100 A/us				

Notes:

1. Measurements made with a 10 Ohm shorting resistor connected between the gate and cathode.

Typical Performance Curves (unless otherwise specified)

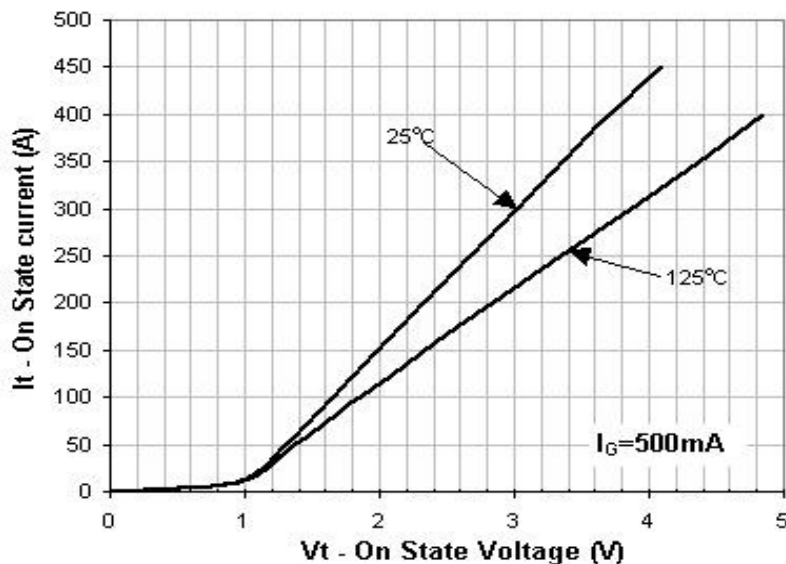

Figure 1.
 Measured Low current
 On-State Characteristics.

Typical Performance Curves (Continued)

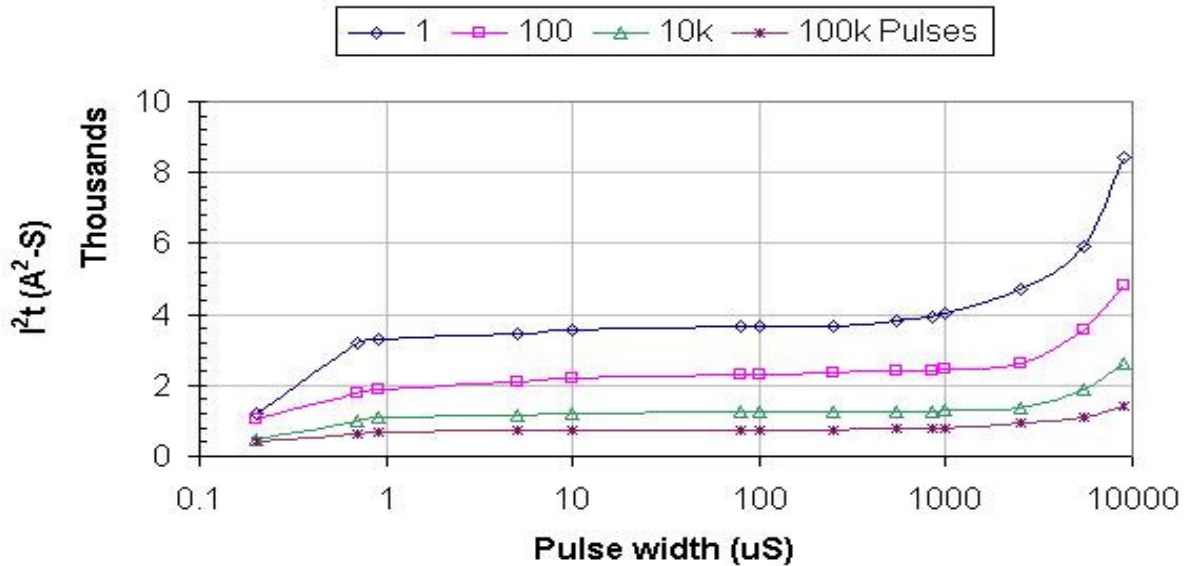
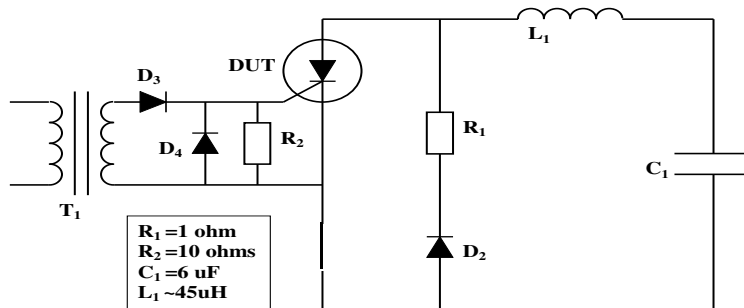
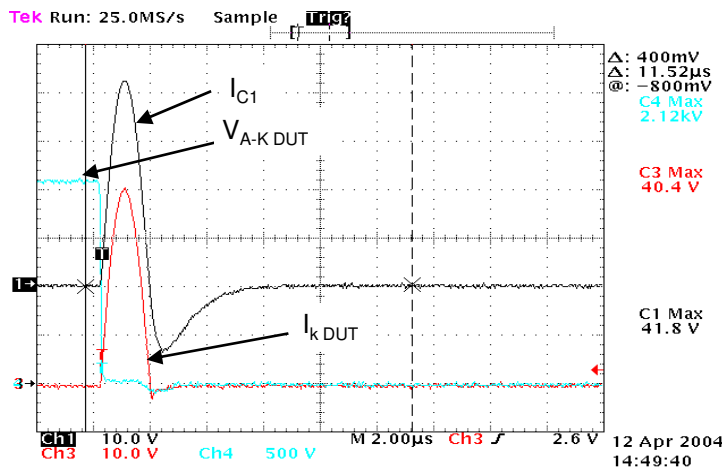

Figure 3. Predicted I^2t data for various number of discharge cycles. Pulses are assumed rectangular. The device junction temperature T_J is assumed to be at 25°C before each discharge event.

Test Circuit



- $L_{\text{SERIES(TOTAL)}}$ can be calculated using equation $1 / (f 2\pi)^2 C$ where $f =$ frequency of I_K when using CCSAC53N30 for circuit set up and calibration.



- The waveform shown is representative of one produced using the test circuit shown where the DUT is the CCSAC53N30 Solidtron. The C1 capacitor voltage in this example was at 2.1kV. I_K peaked at 4kA at 1us and the peak gate current I_g is 1A.

Figure 4. Typical test circuit and waveforms.

Application Notes

A1. Pulse Transformer Gating

A preferred method of isolation, a pulse transformer may be used to predictably and reliably trigger the Thyristor. This gating method allows the user to easily connect the devices in parallel or series (See Fig. A1.2 for series example).

Components (Fig. A1.1)

T₁ - Method of electrically isolating the device from control circuitry. Pulse X-former insulation characteristic must be selected based on application requirements.

R₁ (or **R_{GK}**) - Serves as a keep-off resistor, shunting dv/dt induced, capacitively coupled Anode-Gate current to the Cathode. The lower the value of R₁, the better the dv/dt immunity of the sub-circuit. In the event R₁ must be increased to the point where it's resistance compromises the dv/dt requirement of the application, a low voltage capacitor (.1-.2uF) may be placed in parallel to provide a more responsive shunt path; however, the added capacitance will require more charge be delivered to satisfy the turn-on requirements outlined in the simplified theory of operation.

D₁ & D₂ - Current steering diodes. Reverse gate current increases the impedance of the device ("attempted turn-off"). Reverse gate current experienced during a high current discharge event may permanently damage the device. D₁ restricts the direction of current flow through the secondary while D₂ provides a "free-wheeling" or holding path to the gate.

It is highly recommended that the components listed above, specifically R₁ and D₂ be placed in as close physical/electrical proximity to the device as the application will allow. Parasitic inductance in series with the Gate to Cathode shunt path will also compromise the dv/dt immunity of the device.

Theory of Operation (Refer to Fig. A1.1)

A current pulse supplied to the primary of T₁ induces a current into the secondary of T₁. Current supplied by the T₁ secondary forward biases D₁ supplying current through R₁; thus, developing voltage across R₁ until the gate of the Thyristor is forward biased (~0.7V). Current is then supplied to the Gate of the Thyristor until turn-on (latched-on) is achieved. Following the discharge event, once the Thyristor current reaches zero and it's stored charge is cleared (Storage Time) the circuit is reset and Anode voltage may be reapplied.

Example: Turn-on will occur with R₁=5 ohms, I_{T1-S} => 140mA
It is recommended that T₁ secondary current (I_{T1-S}) => 0.7V / R₁ be supplied for approximately 2uSec. Device turn-on delay (T_{D-ON}) is typically less than 200nSec.

Although I_{T1-S} = 0.7V / R₁ is sufficient to turn the device on, we typically recommend, where possible, I_{T1-S} => >500mA, Pulse Duration => 5uSec with R₁= 10 ohms.

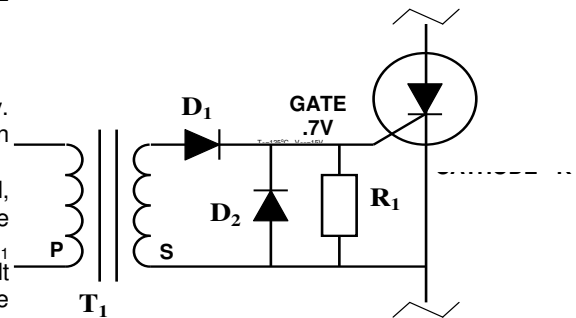

Figure A1.1
Basic Pulse X-Former
Gating Circuit

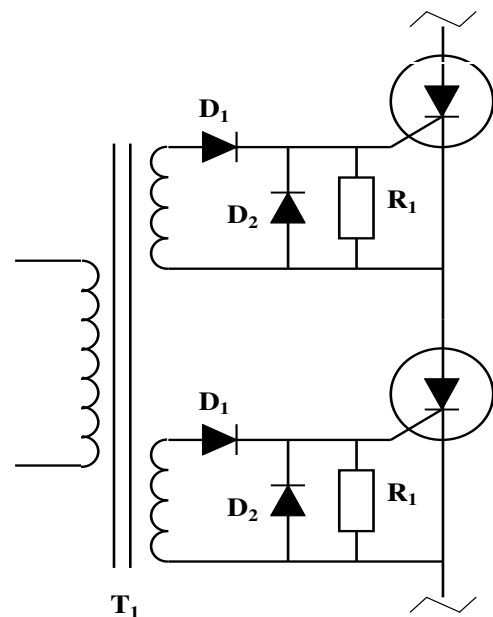
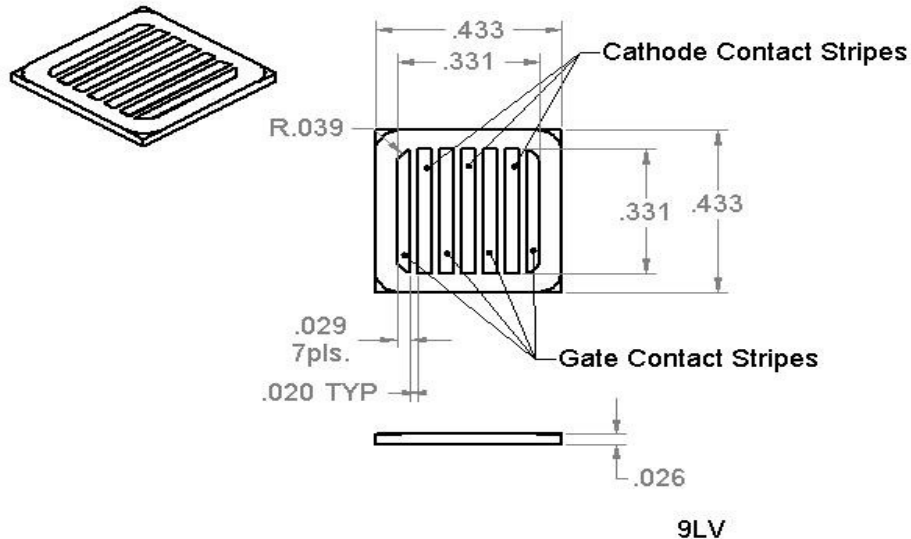

Figure A1.2
Series Connection
Pulse X-Former Gating

Packaging and Handling

1. ATTENTION OBSERVE PRECAUTIONS FOR HANDLING ELECTROSTATIC DISCHARGE SENSITIVE DEVICES IN ALL ASSEMBLY AND TEST AREAS. Proper handling procedures must be observed to prevent electrostatic discharge which may result in permanent damage to the device.
2. The CCSAC53N30 uses an undersized ceramic "lid" which exposes the sensitive Junction Termination Extention (JTE) of the device. The user is required to encapsulate the device in an encapsulant prior to applying high voltage. This prevents debris and contaminants from compromising the JTE.
2. Use of a separate gate return path instead of the cathode power contact is recommended to minimize the effects of rapidly changing Anode-Cathode currents.
3. Shorting resistor R_{GK} is application specific. It can control the gate drive requirements and some device properties. However, $R_{GK} = 10$ Ohms satisfies most application requirements.
4. Installation reflow temperature should not exceed 260°C or internal package degradation may result.

Dimensions



Revision History

Rev	Date	EA #	Nature of Change
0	12-03-2007	04242009-NB-0013	Initial Issue